

**MIL 10000  
DOUBLE PORTED TOP AND BOTTOM  
GUIDED CONTROL VALVES**



**MIL Controls Limited**

## Table of Contents

---

Numbering System.....	2
General Data.....	2
Ratings (ANSI Class).....	3
Temperature Range / Seat Leakage.....	3
Connections.....	3
Critical Flow Factor.....	3
Flow Coefficients.....	4
Cv vs Stroke.....	5,6
Material.....	7,8
Allowable Pressure Drops .....	9-11
Dimensions.....	12,13
Shipping Weights.....	14

## Foreword

---

The 10000 Series double ported control valves are designed to handle a wide variety of process applications. Construction features have been carefully selected to provide optimum performance. These include

### **Top and bottom guiding**

A well accepted industry standard particularly suited for double ported plugs to provide adequate support against side loads.

### **High allowable pressure drops**

Incorporates the simplest form of balanced construction and provides high pressure drop capability with standard actuators.

### **High capacity with low recovery**

Flow capacity is at top levels for contemporary double ported control valves and is attained with very little pressure recovery as indicated by its high critical flow factors.

### **Reduced capacity trim**

Point 4 Factor Trim - the most practical double ported trim design giving a substantial reduction in capacity while maintaining desirable flow characteristics.

### **High performance materials**

Materials of construction have been selected for high performance and long life when handling the high pressure drop capability of the valve.

### **Invertible bodies and plugs**

All 10000 series bodies and plugs are invertible, so either air-to-open or air-to-close action can be obtained with the same spring diaphragm actuator (for Class II leakage).

The following pages provide the necessary technical information required to specify a 10000 series control valve with MIL Type 37 actuators. For additional information, contact your local MIL Representative.

# Numbering System

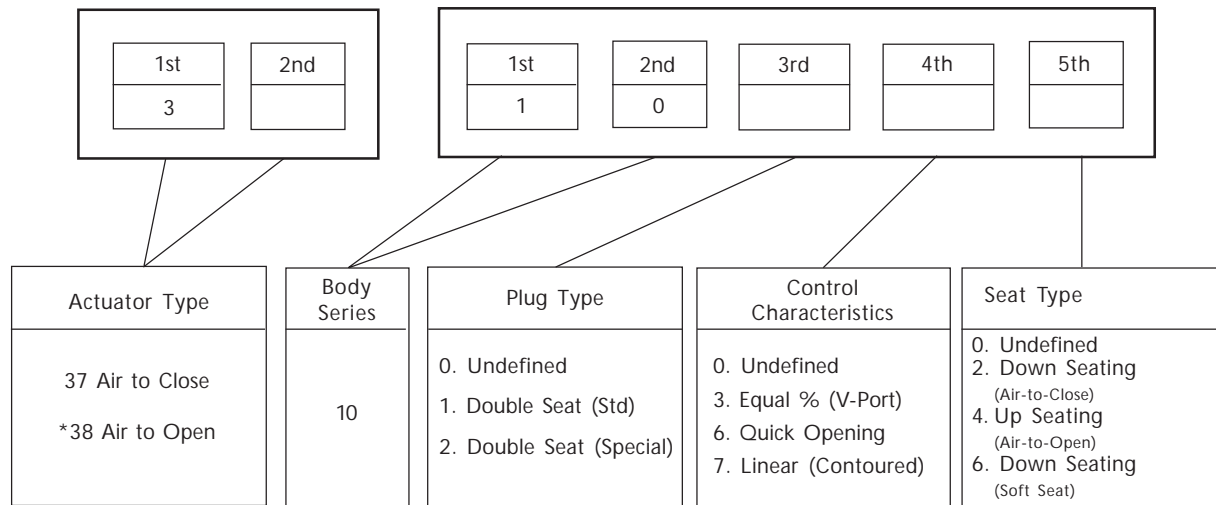

*\*For soft seated valves requiring 'Air fail Close' action*

## General Data

### BODY

Type : Double seat globe  
 Flow direction : Flow passing into the seats  
 Cv ratio : 50:1  
 Bonnet & Blind flange : Bolted  
 Packing box : Bolted

### TRIM

Plug type : Double seat, top and bottom guided  
 Full area and 0.4 factor  
 Optional : Adjustable plug skirts with PTFE inserts  
 (only for contoured)

### FLOW CHARACTERISTICS

Available : Equal percentage, linear and quick opening

### ACTUATOR

Type 37/38 : Pneumatic Spring diaphragm  
 Handwheel : Optional

## Ratings (ANSI Class)

Valve Size (inch)	ANSI Class				
	150	300	600	900	1500
¾ & 1	●	●	●	●	●
1½ to 12	●	●	●	●	●
<sup>(1)</sup> 14 & 16	●	●	●		

<sup>(1)</sup> 20" valve also available. Consult MIL

● Indicates factory standard

## Temperature Range / Seat Leakage

Valve Size (inch)	ANSI Class	Temperature Range		Seat Leakage Class ANSI / FCI 70.2
		Min.	Max.	
¾ to 16	150 to 1500			
		-29°C	+454°C	II / III
		-29°C	+232°C	VI

## Connections

Valve Size (inch)	ANSI Class				
	150	300	600	900	1500
¾	FT	FT	FST	FS	FS
1, 1½ & 2	FT	FT	FST	FS	FS
3 to 12	FB	FB	FB	FB	FB
14 & 16	FB	FB	FB		

F :- RF/RTJ Flanged  
T :- Threaded

B :- Butt Weld  
S :- Socket Weld

Other connections available on request

## Critical Flow Factor - $C_f$

Trim Size	Quick Opening and Linear Plugs (Contoured)	Equal Percentage (V-Port)
Full area	0.90	0.98
<sup>(2)</sup> 0.4 factor	0.80	0.95

<sup>(2)</sup> : Quick opening not available in Point 0.4 trim

## Flow Coefficients - Linear, Equal %

Nominal Trim size	Full Area	¾	1	1½	2	3	4	6	8	10	12	14	16						
	Reduced Area	1½	2	3	4	6	8	10	12										
Orifice Dia (inch)	Upper	0.875	1.063	1.438	1.500	1.876	2.000	2.376	2.625	3.500	4.626	5.250	6.375	7.000	8.750	10.500	12.25	14.000	
	Lower	0.797	0.985	1.355	1.422	1.782	1.906	2.282	2.531	3.406	4.531	5.156	6.250	6.875	8.625	10.375	12.126	13.860	
Valve Size (inch)	Travel (inch)	Rated C <sub>v</sub>																	
¾	0.5	8																	
1	0.5		12																
1½	0.75		11		28														
2	1			19		48													
3	1.5					44		110											
4	1.5						78	195											
6	2							180		450									
8	2.5								300			750							
10	2.5									460				1160					
12	3.5										650					1620			
14	4																	2000*	
16	4																		2560*

\* available with equal percentage plug only.

## Flow Coefficients - Quick Opening

Nominal Trim size	Full Area	¾	1	1½	2	3	4	6	8	10	12
	Orifice Dia (inch)	Upper	0.875	1.063	1.500	2.000	2.625	3.500	5.250	7.000	8.750
	Lower	0.797	0.985	1.422	1.906	2.531	3.406	5.156	6.875	8.625	10.375
Valve Size (inch)	Travel (inch)	Rated C <sub>v</sub>									
¾	0.5	10									
1	0.5		15								
1½	0.75			33							
2	1				60						
3	1.5					140					
4	1.5						250				
6	2							540			
8	2.5								980		
10	2.5									1550	
12	3.5										2250

## Cv Versus Travel (Equal%)

ANSI Class : 150 through 1500

Sizes : 3/4" to 16"

Flow Direction : flow passing into the seats.

Flow Characteristics : equal percentage (v-port)

Percent of Plug Travel			10	20	30	40	50	60	70	80	90	100
C <sub>t</sub>	Full Area Reduced Area		0.99	0.99	0.99	0.99	0.98	0.98	0.98	0.98	0.98	0.98
			0.99	0.99	0.98	0.97	0.96	0.95	0.95	0.95	0.95	0.95
Valve Size (inch)	Orifice Diameter (inch) UPPER LOWER	Travel (inch)	Rated C <sub>v</sub>									
3/4	0.875	0.5	0.24	0.48	0.64	0.88	1.2	1.8	2.3	3.6	5.2	8
	0.797											
1	1.063	0.5	0.36	0.72	0.96	1.3	1.8	2.6	3.5	5.4	7.8	12
	0.985											
1 1/2	1.063	0.75	0.33	0.66	0.88	1.2	1.6	2.4	3.2	4.9	7.1	11
	0.985											
	1.500	0.75	0.84	1.7	2.2	3.1	4.2	6.2	8.1	12.6	18.2	28
	1.422											
2	1.438	1	0.57	1.14	1.5	2.0	2.8	4.18	5.51	8.5	12.3	19
	1.355											
	2.000	1	1.4	2.8	3.8	5.3	7.2	10.5	13.9	21.60	31.2	48
	1.906											
3	1.876	1.5	1.3	2.6	3.5	4.8	6.6	9.7	12.8	19.8	28.6	44
	1.782											
	2.625	1.5	3.3	6.6	8.8	12.1	16.5	24.2	31.90	49.5	71.5	110
	2.531											
4	2.376	1.5	2.3	4.7	6.2	8.6	11.7	17.2	22.6	35.1	50.7	78
	2.282											
	3.500	1.5	5.8	11.7	15.6	21.4	29.2	42.9	56.5	87.7	126	195
	3.406											
6	3.500	2	5.4	10.8	14.4	19.8	27	39.6	52.2	81	117	180
	3.406											
	5.250	2	13.5	27	36	49.5	67.5	99	130	202	292	450
	5.156											
8	4.626	2.5	9	18	24	33	45	66	87	135	195	300
	4.531											
	7.000	2.5	22.5	45	60	82.5	112	165	217	337	487	750
	6.875											
10	5.250	2.5	13.8	27.6	36.8	50.6	69	101.2	133.4	207	299	460
	5.156											
	8.750	2.5	34.8	69.6	92.8	127	174	255	336	522	754	1160
	8.625											
12	6.375	3.5	19.5	39	52	71.5	97.5	143	188.5	292.5	422.5	650
	6.250											
	10.500	3.5	48.6	97.2	129.6	178	243	356	469	729	1053	1620
	10.375											
14	12.251	4	60	120	160	220	300	440	580	900	1300	2000
	12.126											
16	14.000	4	76.8	153	207	281	384	563	742	1152	1664	2560
	13.860											

## Cv Versus Travel (Linear)

ANSI Class : 150 through 1500

Sizes : 3/4" through 12"

Flow Direction : flow passing into the seats.

Flow Characteristics : Linear (contoured)

Percent of Plug Travel			10	20	30	40	50	60	70	80	90	100
C <sub>r</sub>	Full Area Reduced Area		0.60	0.69	0.85	0.90	0.90	0.90	0.90	0.90	0.90	0.90
			0.60	0.69	0.80	0.80	0.80	0.80	0.80	0.80	0.80	0.80
Valve Size (inch)	Orifice Diameter (inch) UPPER LOWER	Travel (inch)	Rated C <sub>v</sub>									
3/4	0.875	0.5	.8	1.6	2.4	3.2	4.0	4.8	5.6	6.4	7.2	8.0
	0.797											
1	1.063	0.5	1.2	2.4	3.6	4.8	6	7.2	8.4	9.6	10.8	12
	0.985											
1 1/2	1.063	0.75	1.1	2.2	3.3	4.4	5.5	6.6	7.7	8.8	9.9	11
	0.985											
	1.500	0.75	2.8	5.6	8.4	11.2	14	16.8	19.6	22.4	25.2	28
	1.422											
2	1.438	1	1.9	3.8	5.7	7.6	9.5	11.4	13.3	15.2	17.1	19
	1.355											
	2.000	1	4.8	9.6	14.4	19.2	24	28.8	33.6	38.4	43.2	48
	1.906											
3	1.876	1.5	4.4	8.8	13.2	17.6	22	26.4	30.8	35.2	39.6	44
	1.782											
	2.625	1.5	11	22	33	44	55	66	77	88	99	110
	2.531											
4	2.376	1.5	7.8	15.6	23.4	31.2	39	46.8	54.6	62.4	70.2	78
	2.282											
	3.500	1.5	19.5	39	58.5	78	97.5	117	136	156	175	195
	3.406											
6	3.500	2	18	36	54	72	90	108	126	144	162	180
	3.406											
	5.250	2	45	90	135	180	225	270	315	360	405	450
	5.156											
8	4.626	2.5	30	60	90	120	150	180	210	240	270	300
	4.531											
	7.000	2.5	75	150	225	300	375	450	525	600	675	750
	6.875											
10	5.250	2.5	46	92	138	184	230	276	322	368	414	460
	5.156											
	8.750	2.5	116	232	348	464	580	696	812	928	1044	1160
	8.625											
12	6.375	3.5	65	130	195	260	325	390	455	520	585	650
	6.250											
	10.500	3.5	162	324	486	648	810	972	1134	1296	1458	1620
	10.375											

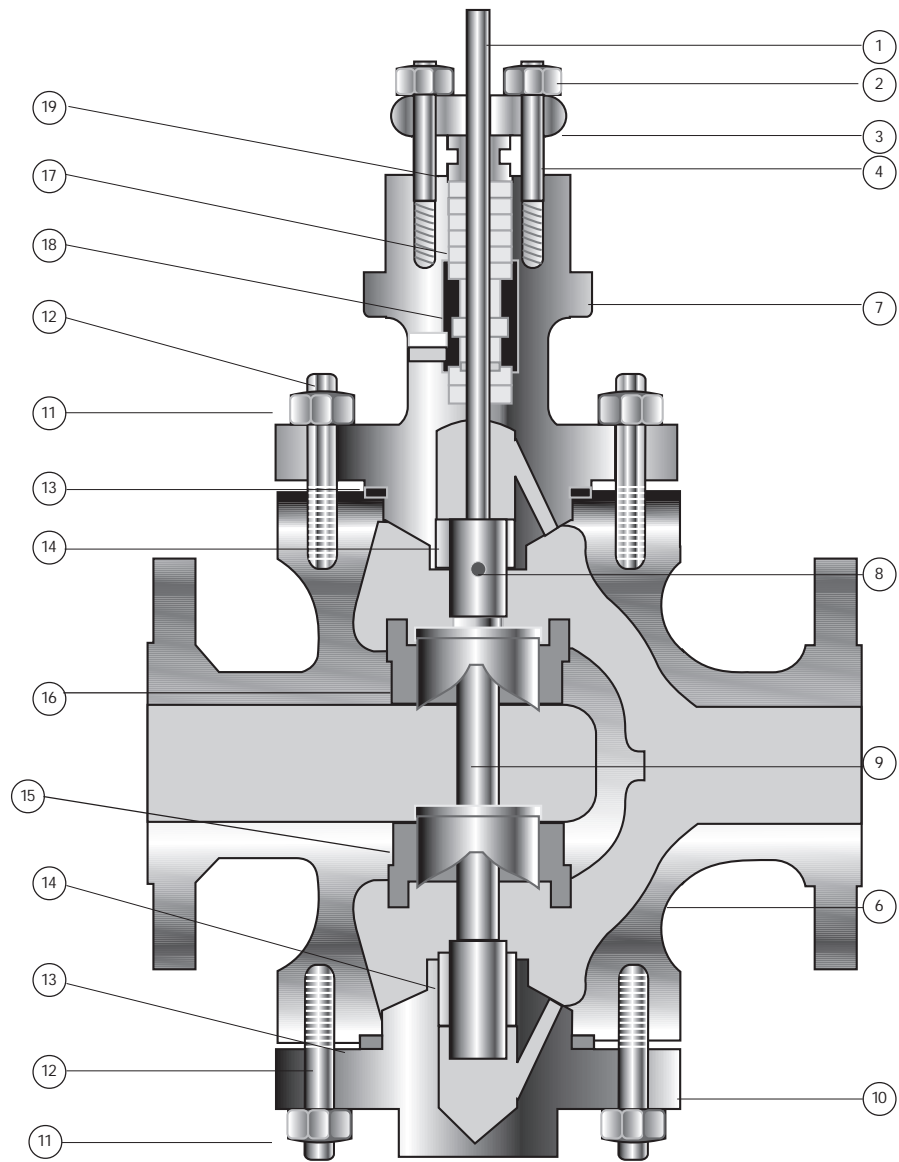

## Material Specifications

Part Ref.	Temperature	-27°C	+232°C	+427°C	+454°C
	Part Name	Standard Materials			
1	Valve Plug Stem	316 Stainless Steel ASTM A479 TY 316			
2	Packing Flange Nut	304 Stainless steel ASTM A 194 Gr 8			
3	Packing Flange	Carbon Steel ASTM A668 CL B, Cadmium Plated			
4	Packing Flange Stud	304 Staleness steel ASTM A 193 Gr B8			
5	Drive Nut	SAE 1117			
6	Body	Carbon Steel ASTM A 216 Gr WCC	(<427°C)		
7	Bonnet	316 St. St. ASTM A351 Gr CF8M			
10	Blind Flange	Alloy Steel ASTM A 217 Gr WC6 / WC9 / C5			
8	Plug Pin	316 St. St. ASTM A479 TY316			
9	Valve Plug	316 Stainless Steel ASTM A479 TY 316 or ASTM A351 Gr CF8M			
		316 Stainless Steel W/Hard Faced Seating Surfaces			
11	Valve Body Stud Nuts	Alloy Steel ASTM A194 Gr 2H			
12	Valve Body Studs	Alloy Steel ASTM A193 Gr B7			
13	Valve Body Gasket	304 St.St. W/Asbestos Filler, Spiral Wound			
		304 St. St. W/Grafoil Filler, Spiral Wound			
14	Guide Bushing	St.St. ASTM A 276 TY440C or Stellite when body is 316 St.St.			
15	Lower Seat Ring	ASTM A351 Gr CF8M or ASTM A182 Gr F316			
16	Upper Seat Ring	316 St. St. W/Hard Faced Seating Surfaces			
17	Packing	Teflon Asbestos	(<232°C)		
		Braided Teflon	(<232°C)		
		Grafoil			
18	Packing Spacer	304 St.St.			
19	Packing Follower	304 St.St.			

Trade names noted throughout text are for reference only

MIL reserves the right to supply trade named material or its equivalent

## Allowable Pressure Drops (Kg/cm<sup>2</sup>) Standard Actuators

Temperature: -27°C to +454°C

Flow Direction: flow passing into the seats

Body Ratings: ANSI Class 150 through 1500

Seat Leakage : Per ANSI/FCI 70.2, Class II

Valve Size in.	Travel In.	Rated C <sub>v</sub>		Actuator Size	Valve Plug Position	Allowable Pressure Drops (kg/cm <sup>2</sup> ) ① ②								Side Mounted Aux. Handwheel
		Equal% Linear	Quick Opening			Air-to-Open				Air-to-Close				
						Range ③	A ④	B ⑤	C ⑥	Range ③	A ④	B ⑤	C ⑥	
¾	0.5	8	10	11	Closed	7-17	239	246	239	3-9	253	253	253	6A1
		12	15		Open		120	155	155		155	253	253	
1½	0.75	28	33	11	Closed	7-17	167	167	164	3-12	160	165	165	
					Open		35	56	77		77	165	165	
	0.75	11	-	11	Closed	6-16	190	190	190	3-12	120	239	239	
					Open		105	105	105		120	239	239	
2	1	48	60	11	Closed	5-18	62	62	62	3-15	49	49	49	
					Open		14	25	41		38	49	49	
	1	48	60	11	Closed	6-30	83	83	83	6-30	49	49	49	
					Open		35	60	102		49	49	49	
	1	19	-	11	Closed	5-18	97	98	98	3-15	79	80	79	
					Open		43	51	51		79	80	79	
	1	19	-	11	Closed	6-30	130	132	132	6-30	79	80	79	
					Open		105	125	124		79	80	79	
3	1.5	110	140	13	Closed	7-17	110	110	110	3-15	56	56	56	
					Open		18	34	63		27	56	56	
	1.5	110	140	13	Closed	6-30	88	88	88	6-30	56	56	56	
					Open		31	56	88		54	56	56	
	1.5	44	-	13	Closed	7-17	156	159	158	3-15	78	80	102	
					Open		70	107	110		78	80	102	
	1.5	44	-	13	Closed	6-30	124	127	126	6-30	78	80	102	
					Open		115	127	126		78	80	102	
4	1.5	195	250	13	Closed	7-17	82	82	82	3-15	42	42	42	
					Open		11	21	41		14	30	42	
	1.5	195	250	13	Closed	6-30	65	65	65	6-30	42	42	42	
					Open		18	34	65		28	42	42	
	1.5	78	-	13	Closed	7-17	120	123	123	3-15	63	63	63	
					Open		49	82	113		63	63	63	
	1.5	78	-	13	Closed	6-30	96	98	98	6-30	63	63	63	
					Open		82	98	98		63	63	63	
6	2	450	540	15	Closed	3-15	13	13	13	3-15	39	39	39	
					Open		11	13	13		8	18	39	
	2	450	540	15	Closed	6-30	62	62	62	6-30	39	39	39	
					Open		11	20	39		18	37	39	
	2	180	-	15	Closed	3-15	20	20	20	3-15	58	60	57	
					Open		20	20	20		58	60	57	
	2	180	-	15	Closed	6-30	94	96	95	6-30	58	60	57	
					Open		53	91	95		58	60	57	

① Pressure drops must not exceed the ANSI body rating.

② Inlet pressure must not exceed the allowable pressure drop.

③ 6-30 psi ranges require a 35 psig air supply; all other ranges require a 20 psig air supply.

④ A - Linear & quick-opening plugs on liquid service

⑤ B - Linear & quick-opening plugs on gas & steam service

- Equal percentage plug on liquid service

⑥ C - Equal percentage plug on gas & steam service

## Allowable Pressure Drops (Kg/cm<sup>2</sup>) Standard Actuators

Temperature: -27°C to +454°C

Flow Direction: flow passing into the seats

Body Ratings: ANSI Class 150 through 1500

Seat Leakage : Per ANSI/FCI 70.2, Class II

Valve Size in.	Travel In.	Rated C <sub>v</sub>		Actuator Size	Valve Plug Position	Allowable Pressure Drops (kg/cm <sup>2</sup> ) ① ②								Side Mounted Aux. Handwheel
		Equal% Linear	Quick Opening			Air-to-Open				Air-to-Close				
						Range ③	A ④	B ⑤	C ⑥	Range ③	A ④	B ⑤	C ⑥	
8	2.5	750	980	18	Closed	3-15	11	12	11	3-15	34	39	36	6A3
					Open		10	12	11		7	15	36	
	2.5	750	980	18	Closed	6-30	53	60	56	6-30	34	39	36	
					Open		10	19	39		15	33	36	
	2.5	300	-	18	Closed	3-15	21	23	22	3-15	69	72	70	
					Open		21	23	22		51	72	70	
	2.5	300	-	18	Closed	6-30	108	113	112	6-30	69	72	70	
					Open		51	88	112		69	72	70	
10	2.5	1160	1550	18	Closed	3-15	5	6	6	3-15	31	35	33	
					Open		5	6	6		4	8	20	
	2.5	1160	1550	18	Closed	6-30	39	46	42	6-30	31	35	33	
					Open		7	13	28		9	20	33	
	2.5	460	-	18	Closed	3-15	12	12	12	3-15	68	71	70	
					Open		12	12	12		34	56	70	
	2.5	460	-	18	Closed	6-30	89	91	89	6-30	68	71	70	
					Open		44	78	89		68	71	70	
12	3.5	1620	2250	18 (16)	Closed	-	-	-	-	3-15	21	29	25	8A
					Open		-	-	-		3	4	12	
	3.5	1620	2250	18 (16)	Closed	6.30	23	31	27	6.30	21	29	25	
					Open		5	7	20		21	10	29	
	3.5	650	-	18 (16)	Closed	3-15	2	2	2	3-15	50	55	53	
					Open		2	2	2		19	32	53	
	3.5	650	-	18 (16)	Closed	6-30	58	58	58	6-30	50	53	53	
					Open		32	55	58		47	53	53	
14	4	2000	-	18 (16)	Closed	-	-	-	-	3-15	15	24	21	
					Open		-	-	-		1	2	7	
	4	2000	-	18 (16)	Closed	6-30	13	20	18	6-30	15	24	21	
					Open		4	5	15		4	6	19	
16	4	2560	-	18 (16)	Closed	-	-	-	-	3-15	11	21	18	
					Open		-	-	-		1	1	4	
	4	2560	-	18 (16)	Closed	6-30	8	14	13	6-30	12	21	18	
					Open		3	4	12		3	4	13	

① Pressure drops must not exceed the ANSI body rating.

② Inlet pressure must not exceed the allowable pressure drop.

③ 6-30 psi ranges require a 35 psig air supply; all other ranges require a 20 psig air supply.

④ A - Linear & quick-opening plugs on liquid service

⑤ B - Linear & quick-opening plugs on gas & steam service  
- Equal percentage plug on liquid service

⑥ C - Equal percentage plug on gas & steam service

## Allowable Pressure Drops (Kg/cm<sup>2</sup>) - With Oversize Actuators

Temperature: -27°C to +454°C

Flow Direction: flow passing into the seats

Body Ratings: ANSI Class 150 through 1500

Seat Leakage : Per ANSI/FCI 70.2, Class II

Valve Size in.	Travel In.	Rated C <sub>v</sub>		Actuator Size	Valve Plug Position	Allowable Pressure Drops (kg/cm <sup>2</sup> ) ① ②								Side Mounted Aux. Handwheel
		Equal% Linear	Quick Opening			Air-to-Open				Air-to-Close				
						Range ③	A ④	B ⑤	C ⑥	Range ③	A ④	B ⑤	C ⑥	
2	1	48	60	13	Closed	3-15	28	28	28	3-15	75	75	75	6A2
					Open		28	28	28		53	75	75	
					Closed	6-30	117	117	117	6-30	75	75	75	
					Open		53	93	117		75	75	75	
3	1.5	110	140	15	Closed	3-15	31	31	31	3-15	77	77	77	
					Open		31	31	31		39	77	77	
					Closed	6-30	129	129	129	6-30	77	77	77	
					Open		44	79	129		77	77	77	
4	1.5	195	250	15	Closed	3-15	23	23	23	3-15	59	59	59	6A3
					Open		23	23	23		20	44	59	
					Closed	6-30	96	96	96	6-30	59	59	59	
					Open		25	48	94		41	59	59	
6	2	450	540	18	Closed	3-15	23	23	23	3-15	58	58	58	
					Open		15	23	23		13	28	58	
					Closed	6-30	98	98	98	6-30	58	58	58	
					Open		15	30	60		27	58	58	
8	2.5	750	980	24	Closed	3-15	18	20	19	3-15	53	59	56	
					Open		15	20	19		12	25	56	
					Closed	6-30	84	95	89	6-30	53	59	56	
					Open		15	30	61		25	51	56	
10	2.5	1160	1550	24	Closed	3-15	11	13	12	3-15	46	53	49	
					Open		11	13	12		7	14	33	
					Closed	6-30	64	75	69	6-30	46	53	49	
					Open		11	20	43		15	31	49	
12	3.5	1620	2250	24	Closed	3-15	5	6	6	3-15	30	40	35	
					Open		5	6	6		4	7	21	
					Closed	6-30	39	53	46	6-30	53	40	63	
					Open		11	8	44		10	16	48	
14	4	2000	-	24	Closed	3-18	1	1	1	3-18	21	33	29	
					Open		1	1	1		3	4	13	
					Closed	6-30	24	37	32	6-30	21	33	29	
					Open		5	7	21		6	10	13	
16	4	2560	-	24	Closed	3-18	-	-	-	3-18	16	28	24	
					Open		-	-	-		2	3	9	
					Closed	6-30	16	27	24	6-30	16	28	24	
					Open		4	5	24		5	7	23	

① Pressure drops must not exceed the ANSI body rating.

② Inlet pressure must not exceed the allowable pressure drop.

③ 6-30 psi ranges require a 35 psig air supply; all other ranges require a 20 psig air supply.

④ A - Linear & quick-opening plugs on liquid service

⑤ B - Linear & quick-opening plugs on gas & steam service  
- Equal percentage plug on liquid service

⑥ C - Equal percentage plug on gas & steam service

# Dimensions (Inch)

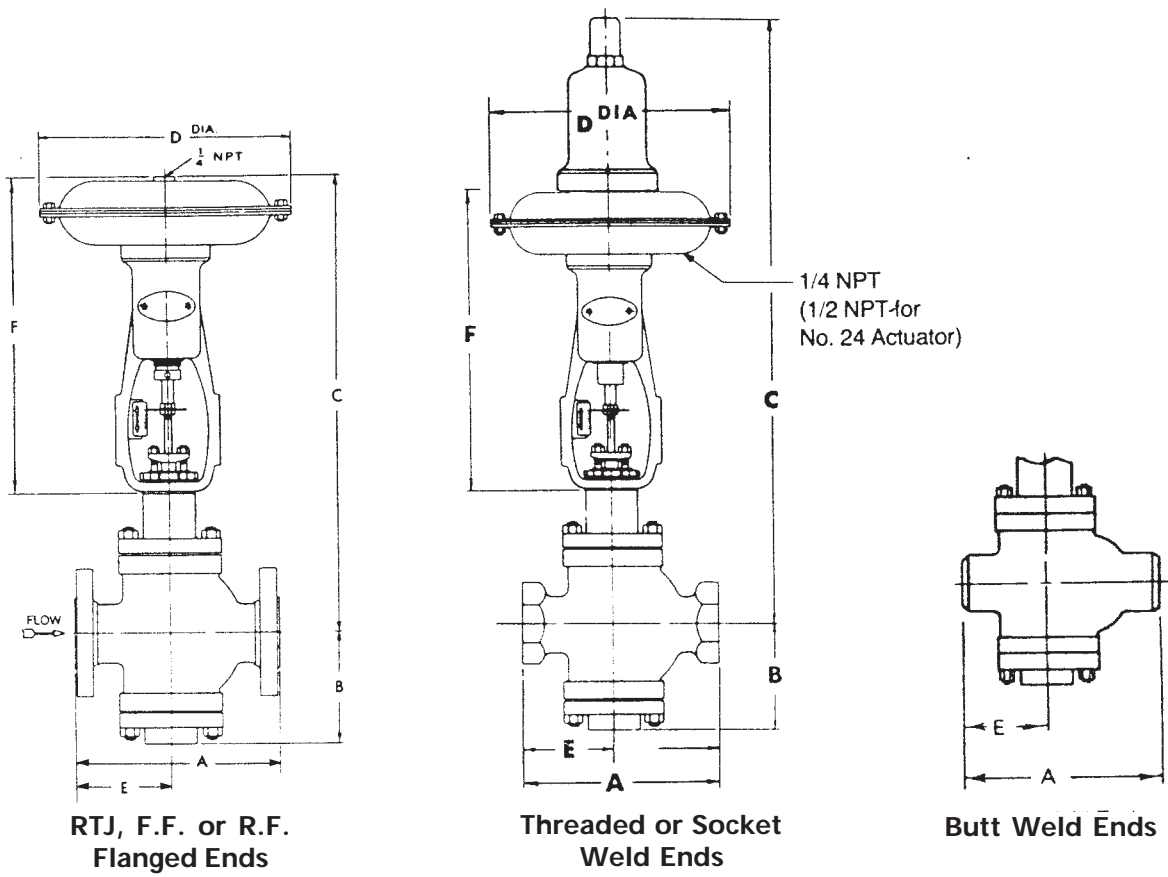

Valve Size (inch)	ANSI Class 600 Threaded-Socket Weld and Butt Weld		ANSI Class 150 Raced Face		ANSI Class 150 Ring Type Joint		ANSI Class 300 Raced Face		ANSI Class 300 Ring Type Joint		ANSI Class 600 Raised Face		ANSI Class 600 Ring Type Joint		B (Max)
	A	E	A	E	A	E	A	E	A	E	A	E	A	E	
3/4	6.00	2.88	7.25	3.62	-	-	7.62	3.81	8.12	4.06	8.12	4.06	8.12	4.06	4.5
1	6.00	2.88	7.25	3.62	7.75	3.88	7.75	3.88	8.25	4.12	8.25	4.12	8.25	4.12	4.5
1 1/2	8.00	3.69	8.75	4.06	9.25	4.31	9.25	4.31	9.75	4.56	9.88	4.62	9.88	4.62	5.4
2	9.25	4.12	10.00	4.62	10.50	4.88	10.50	4.88	11.12	5.19	11.25	5.25	11.38	5.31	6.0
3	13.25	6.25	11.75	5.50	12.25	5.75	12.50	5.88	13.12	6.19	13.25	6.25	13.38	6.31	7.8
4	15.50	7.38	13.88	6.56	14.38	6.81	14.50	6.88	15.12	7.19	15.50	7.38	15.62	7.44	8.1
6	20.00	8.75	17.75	7.62	18.25	7.88	18.62	8.06	19.25	8.38	20.00	8.75	20.12	8.81	11.2
8	24.00	9.88	21.38	8.56	21.88	8.81	22.38	9.06	23.00	9.38	24.00	9.88	24.12	9.94	13.4
10	27.75	11.50	24.62	9.94	25.12	10.19	26.00	10.62	26.62	10.94	27.75	11.50	27.88	11.56	14.8
12	32.00	12.88	28.75	11.25	29.25	11.50	30.25	12.00	30.88	12.31	32.00	12.88	32.12	12.94	17.8
14	36.75	14.62	33.50	13.00	34.00	13.25	35.00	13.75	35.62	14.06	36.75	14.62	36.88	14.68	21.50
16	38.63	17.25	35.38	15.69	35.88	15.94	36.88	16.50	37.50	16.81	38.63	17.25	38.75	17.31	22.30

Note : See Page 13 for ANSI Class 900-1500 and actuator dimensions

## Dimensions (Inches)

ANSI Class : 900-1500

All dimensions in inches

Valve Size (inch)	ANSI Class 900 Raced Face		ANSI Class 900 Ring Type Joint		ANSI Class 1500 Raced Face		ANSI Class 1500 Ring Type Joint		ANSI Class 900 & 1500 Buttor Socket Weld		B (Max)
	A	E	A	E	A	E	A	E	A	E	
¾	9.50	4.75	9.50	4.75	9.50	4.75	9.50	4.75	9.50	4.75	45
1	9.75	4.88	9.75	4.88	9.75	4.88	9.75	4.88	9.75	4.88	45
1½	10.62	5.12	10.62	5.12	10.62	5.12	10.62	5.12	10.62	5.12	54
2	12.25	5.88	12.38	5.94	12.25	5.88	12.38	5.94	12.25	5.88	60
3	15.25	7.12	15.38	7.19	16.00	7.50	16.12	7.56	16.00	7.50	78
4	18.25	8.62	18.38	8.69	19.00	9.00	19.12	9.06	19.00	9.00	81
6	20.88	9.44	21.00	9.50	24.00	11.00	24.25	11.12	24.00	11.00	112
8	27.88	12.75	28.00	12.81	30.12	13.88	30.50	14.06	30.12	13.88	134
10	32.62	15.12	32.75	15.19	35.62	16.62	36.00	16.81	35.62	16.62	148
12	35.25	15.62	35.38	15.69	40.38	17.69	41.00	18.00	40.38	17.69	178
14	-	-	-	-	-	-	-	-	-	-	215
16	-	-	-	-	-	-	-	-	-	-	223

Note : Consult MIL Controls Ltd. for 14" and 16" valve dimensions.

## Actuator Dimensions

Valve Size (inch)	Actuator Size	C Direct	C Reverse	D	F
¾		29.7	22.0	130	164
1	11	29.7	22.0	130	164
1½	11	30.2	22.5	130	164
2	11	31.3	23.6	130	164
	13	36.9	27.4	150	201
3	13	38.9	29.4	150	201
	15	44.5	34.6	175	254
4	13	39.1	29.6	150	201
	15	44.9	35.0	175	254
6	15	47.9	38.0	175	254
	18	49.5	39.5	208	269
8	18	51.6	41.6	208	269
	24	60.3	49.5	275	348
10	18	53.3	43.3	208	269
	24	61.9	51.1	275	348
12	18(16)	62.0	53.1	208	333
	24	65.4	54.6	275	348
14	18(16)	66.3	57.4	208	333
	24	69.7	58.9	275	348
16	18(16)	68.3	59.4	208	333
	24	71.7	60.9	275	348

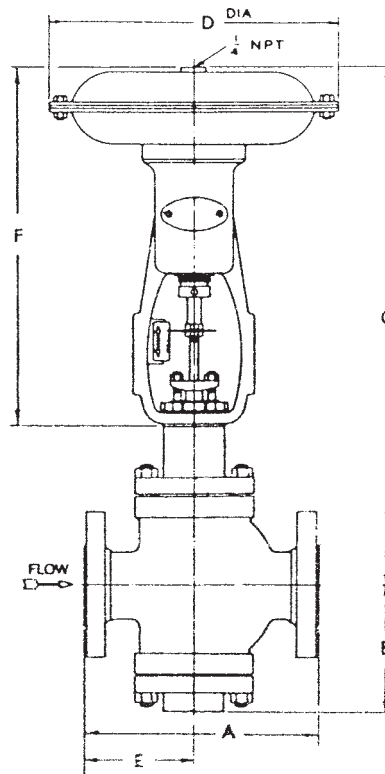

## Aproximate Shipping Weights (Lbs)

### Body Sub-assemblies

Valve Size (inch)	Cast Iron	Socket Butt Weld & Threaded Ends up to 600 lbs	Flanged				
			ANSI 150	ANSI 300	ANSI 600	ANSI 900	ANSI 1500
¾	90	40	80	80	90	162	162
1	90	45	85	85	100	180	180
1½	105	45	105	110	120	216	216
2	145	50	150	160	175	297	297
3	220	110	245	255	270	397	408
4	285	192	305	310	335	392	505
6	470	364	515	530	595	892	910
8	650	669	800	825	960	1440	1460
10	1250	1168	1350	1380	1500	2250	2250
12	1350	1452	1700	1740	1900	2850	2850

Note : Consult MIL for 14" & 16" shipping weights

### Actuator Sub-assembly Weights - lbs

Size	Action	
	Direct	Reverse
11	45	55
13	70	87
15	120	140
18	180	250
18(16)	190	370
24	325	240

### Handwheel Sub-Assemblies

Type	Weight lbs
6A1	19
6A2	45
6A3	75
8A(#18)	40
7A(#24)	75



**MIL Controls Limited**  
A KSB Company



**REGD. OFFICE & WORKS**

Meladoor, Mala  
PIN 680 741, Thrissur Dist., Kerala, India  
T: 91 (0)488 890272, 890772, 891773  
F: 91 (0)488 890952  
E: milf@vsnl.com

**MARKETING HEAD OFFICE**

P. B. No. 04, Aluva  
PIN 683 101, Ernakulam Dist, Kerala, India  
T: 91 (0)484-624955, 624876  
F: 91 (0)484-623331  
E: ksbnmil@sancharnet.in, milksb1@vsnl.net

**BRANCH OFFICES**

**NEW DELHI**  
MIL Controls Limited  
KSB House, A-96, Sector 04,  
Gautam Budh Nagar,  
Noida 201 301, India  
Tel: 91 (0)120 4541091 to 93, 4541501 to 03  
Fax: 91 (0)120 4550567, 4525626  
Email: ksbdel@ndf.vsnl.net.in

**MUMBAI**  
MIL Controls Limited  
Batra House, 2nd Floor, Saki Naka,  
Andheri (E),  
Mumbai 400 072, India  
Tel: 91 (0)22 8528614 to 15, 8528617  
Fax: 91 (0)22 8528618  
Email: milimum@bom3.vsnl.net.in

**CALCUTTA**  
MIL Controls Limited  
2nd Floor, 30 Circus Avenue,  
Calcutta 700 017, India  
Tel: 91 (0)33 2470473, 2400117, 2400418  
Fax: 91 (0) 33 2470588  
Email: milcal@vsnl.net

**CHENNAI**  
MIL Controls Limited  
Guindy House, 2nd Floor,  
95, Annal Salai,  
Chennai 600 032, India  
Tel: 91 (0) 44 2352571 to 72, 2300629  
Fax: 91 (0) 44 2352749  
Email: che-mil@ksb.co.in

**VADODARA**  
MIL Controls Limited  
4-B, Ramakrishna Chambers,  
Productivity Road,  
Vadodara 390 005, India  
Tel: 91 (0)265 330532, 333226  
Fax: 91 (0)265 314693  
Email: ksbad1@sancharnet.in

**POONA**  
MIL Controls Limited,  
Sawant Nivas, 1194/7 Ghole Road,  
Near Ramachandra Mandap, Shivaji Nagar,  
Poona 411 005, India  
Tel: 91 (0)20 5536345, 5536347, 5530012  
Fax: 91 (0)20 5536349  
Email: ksbpune@vsnl.net

**OVERSEAS SALES OFFICES**

**AUSTRALIA**  
KSB Ajax Pumps Pty Ltd,  
27 Indwe Street, Tottendam,  
Victoria 3012, Australia  
Tel: (61-3) 9314 0611  
Fax: (61-3) 9314 7435  
Email: ksbcentra@ksbajax.com.au

**CHINA**  
KSB-AMRI BEIJING,  
Unit 1102, The Gateway,  
No. 10 Yabao Road, Chao yang District,  
Beijing 100020, China  
Tel: (86-10) 6591 5768  
Fax: (86-10) 6591 5769  
Email: amribj@public.fhnet.cn.net

**FINLAND**  
Mercantile KSB Oy Ab,  
Tuotekatu 04, FIN 33840  
TAMPERE, Finland  
Tel: 358 9 3450 5112  
Fax: 358 9 3450 5123  
Email: anssi.lahti@ksb.mercantile.fi

**HONG KONG**  
KSB Limited,  
17/F, Chuang's City Tower,  
39 Morrison Hill Road,  
Causeway Bay, Hong Kong  
Tel: 852 2147 1220  
Fax: 852 2147 1230  
Email: ksb\_hk@pacific.net.hk

**INDONESIA**  
PT KSB  
J1 Boulevard, Timur Block,  
NC 1/53, Kelapa Gading Permai,  
Jakarta 13220, Indonesia  
Tel: 62-21 4584 2070  
Fax: 62-21 4584 2071  
Email: ksbindo@centrin.net.id

**SOUTH KOREA**  
KSB Korea Ltd,  
6F, Doo Kyong Building,  
6401 Hannam - Dong, Yongsan - Ku,  
Seoul, South Korea  
Tel: 82-2 790 4351  
Fax: 82-2 790 4350  
E-mail: ksbkorea@ppp.kornet.net

**MALAYSIA**  
KSB AMRI Sdn Bhd,  
65-2 Jalan 51/205, Highway Centre,  
4605 Petaling Jaya,  
Selangor Darul Ehsan, Malaysia  
Tel: 60-03 7781 3026  
Fax: 60-03 7781 3020  
Email: ksbamri@pd.jaring.my

**SINGAPORE**  
KSB AMRI (Asia Pacific) Pte Ltd  
25 Tagore Lane, 02-08/09  
Singapore Godown, Singapore 787602  
Tel: 65 555 0366  
Fax: 65 553 3500  
Email: sales@ksb-amri.com.sg

**SOUTH AFRICA**  
KSB Pumps (S.A) Pty Ltd,  
P.O. Box 2938, Primrose 1416,  
Cor. North Reef & Activia Road, Activia Park,  
Germiston, South Africa  
Tel: 27-11 828 8950  
Fax: 27-11 282 0244  
Email: valves@ksbpumps.co.za

**TAIWAN**  
KSB Taiwan Co Ltd,  
19F Room A 1, Taiwan Leaders Center,  
No. 29, Hai-Pien Road, Kaohsiung, Taiwan ROC  
Tel: 886-7 330 7724  
Fax: 886-7 330 7548  
Email: ksbkhh@ksmail.seed.net.tw

